

# SC-35W Series UPS charger



## Features:

- Universal AC input/Full range
- Small volume, low weight, high efficiency
- Protections: Short circuit / Overload
- Indicator for power on/charge/normal(LED)
- 100% full load burn-in test
- Battery protection at low voltage
- 2 Years warranty



Dimension: 111 × 78 × 36mm

## SPECIFICATION

Model		SC-35-12		SC-35-24	
Output	DC voltage	CH1:13.8V	CH2:13.4V	CH1:27.6V	CH2:26.5V
	Voltage tolerance	± 2%	-----	± 1%	-----
	Rated current	2.0A	0.5A	1.0A	0.3A
	Current range	0 ~ 2.0A	-----	0 ~ 1.0A	-----
	Rated power	34.3W		35.6W	
	Ripple & noise	120mVp-p	-----	120mVp-p	-----
	DC voltage ADJ. range	CH1:11.3 ~ 14.9V		CH1:21.3 ~ 29.8V	
	Setup, rise, hold up time	800ms,50ms,80ms/230VAC.1600ms,50ms,16ms/115VAC.			
Input	Voltage range	90 ~ 264VAC or 127 ~ 370VDC			
	AC current	0.9A/115VAC 0.45A/230VAC			
	Efficiency	81%		83%	
	Inrush current	cold-start current 25A/115VAC 45A/230VAC			
	leakage current	< 1mA/240VAC			
Protection	over load	rated output power 110% ~ 150% start over load protection			
		protection type: AC charging mode :hiccup mode, auto-recovery after fault condition is removed			
	battery protection at low voltage	9.5 ~ 11V		20 ~ 22V	
		protection mode :cutoff output			
Function	UPS introduction	long-term online floating charge to battery,high charging efficiency,battery can saturate to more than 90%			
		auto-stop charging when it's full,prevent over charging. Effectively extend battery life			
		AC/battery auto switch,no switch time,no need human guard			
		cold-start ,when there is no AC input ,can use battery start UPS,Meet the user's emergency needs			
Environment	Working temp, humidity	-20°C ~ +50°C;20% ~ 90%RH(Please refer to "derating curve" )			
	Storage temp, humidity	-40°C ~ +85°C;10% ~ 95%RH Non-condensing			
	Withstand vibration	10 ~ 500Hz, 55G 10min./1Cycle, Period for 60min, Each axes			
Safety	Withstand voltage	I/P-O/P: 1.5KVAC I/P-FG: 1.5KVAC O/P-FG: 0.5KVAC			
	Isolation resistance	I/P-O/P: I/P-FG,O/P-FG: 100M Ohms/500VDC			
Fit standard	Safety standard	Compliance to UL 62368-1,TUV 62368-1,EN62368-1			
	EMC Standard	Compliance to EN 55032 CLASS A			
Others	Weight	129*97*38mm ( L*W*H )			
	Packing	0.3kg/50pcs/16kg			

Note: 1. All parameters NOT specially mentioned are measured at 230VAC input, rated load and 25°C of ambient temperature.

2. Ripple & noise are measured at 20MHz of bandwidth by using a 12" twisted pair-wire terminated with a 0.1uf & 47uf parallel capacitor.

3. Tolerance : includes set up tolerance, line regulation and load regulation

# SC-35W Series UPS charger

## Mechanical specification

Unit:mm

### PIN assignment

Pin NO.	Assignment
1	AC/L
2	AC/N
3	FG
4	DC -V
5	DC +V

### circumscribed indicator explain

indicator color	explain
green	DC OUTPUT indicator
red	AC INPUT indicator
white	battery charge indicator

cold-start ,when there is no AC input ,can use battery start UPS,Meet the user's emergency needs

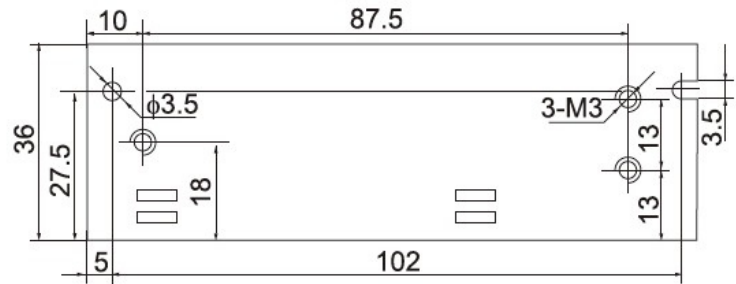
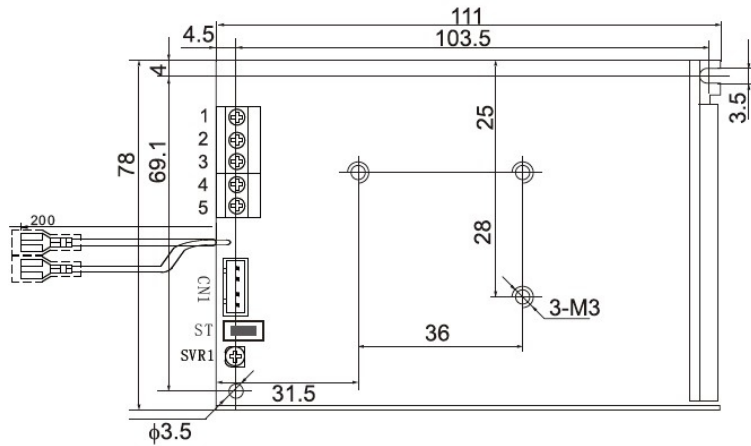

## Block diagram

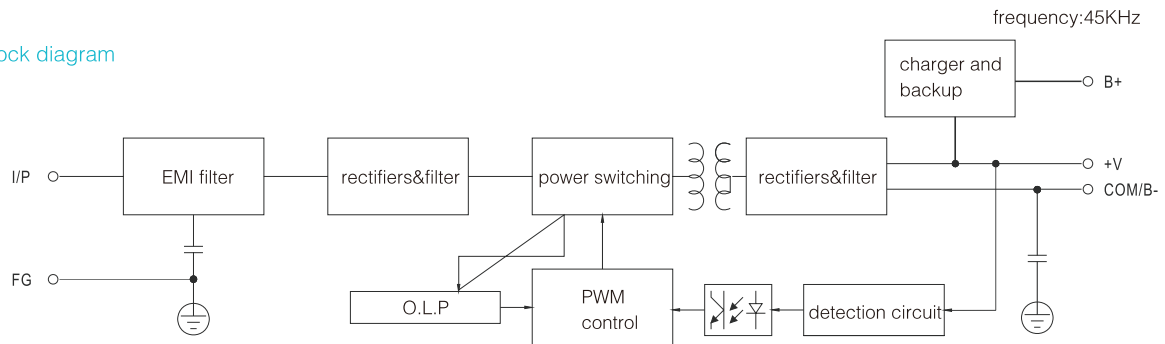

## Derating curve

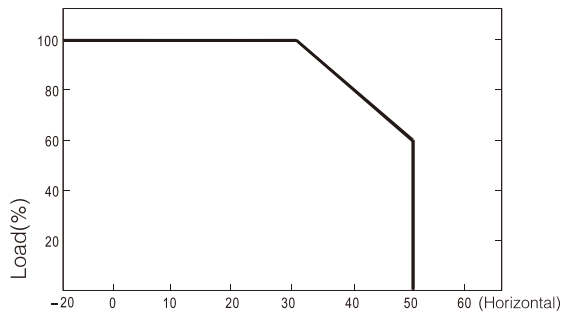

Ambient temperature(°C)

## Static characteristic

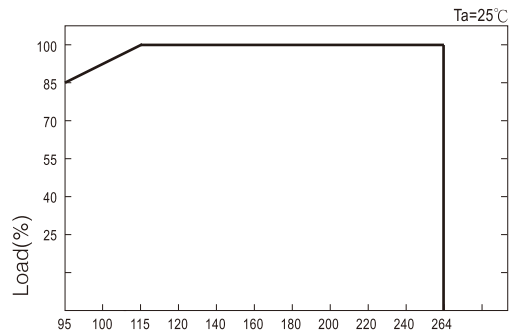

Input voltage(V)50Hz